

# Ultrasonik

VETRON

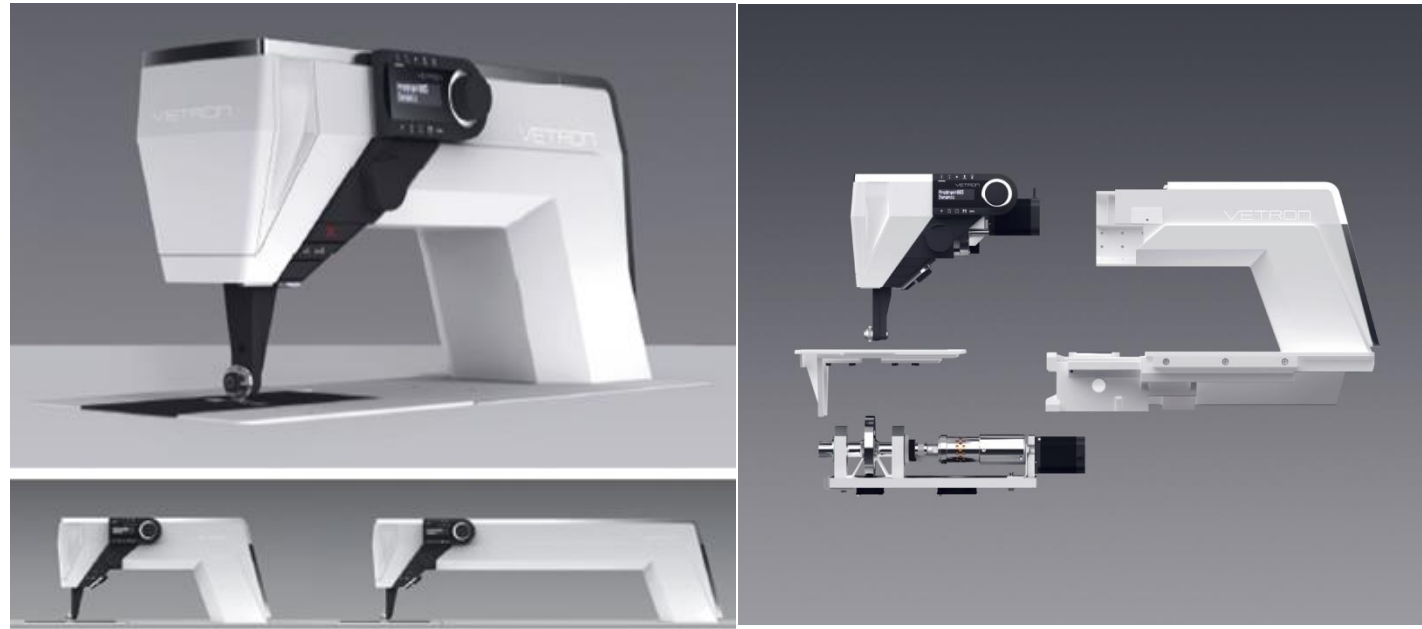

## » ULTRASONİK YAPIŞTIRMA MAKİNALARI



» VETRON 5044

» VETRON 5144

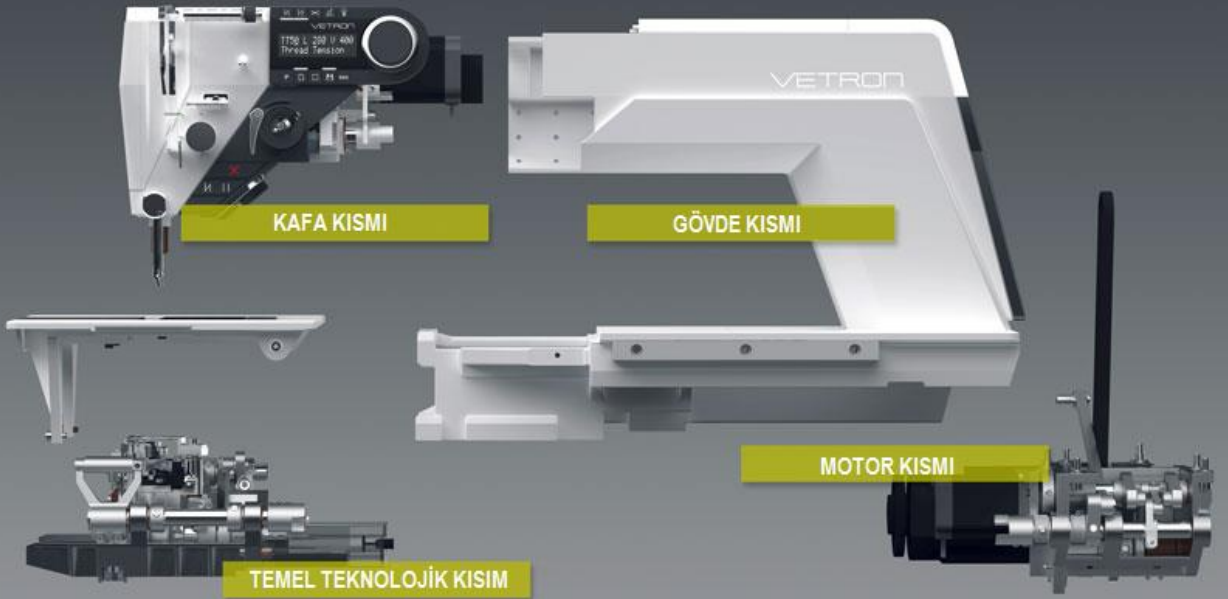

VETRON markası tekstil ve deri işlemlerinde, birçok ödül almış yenilikçi çözümler ve profesyonel hizmet kalitesi ile müşterinin ihtiyaçlarına odaklanmış olarak Alman mühendisliğinin sanatı ve profesyonel servis hizmetleri ile geliştirilmiş yüksek ürünler anlamına gelir.

Ürünler yüksek teknoloji kullanımı ile Avrupa ve Asya'da seçilen bileşenler ile yapılmış, olup üstün güvenlik, yeni standartlar, üstün bir fiyat performans oranı ve yenilikçi işlevsellik sunan yapıdadır.

Operatörleri ve servis teknisyenleri için, kolay ergonomik ve net arayüzü yapı tasarımı sırasında bir önceliktir.

texprocess  
innovationaward



Focus Open  
Silber 2011



Frankfurt Texprocess'de 2011 yılında Vetron "Texprocess İnovasyon Ödülü" ile ödüllendirildi ve Designzentrum Stuttgart tarafından "Focus 2011" adlı tasarım ödülüne layık görüldü.

## » AYAK ÇEŞİTLERİ

» (Scale 1:1)  
» (Maßstab 1:1)

	WATT			Ti		Fe			
5064-	1000	500	40	25 / 45	-			10	9.5
	2000	1,000	40	25 / 45	-			10	9.5
	2300	1,000	40	25 / 45	-	*	*	13	12.5
5164-	1000	500	40	25 / 45	-			10	9.5
	2000	1,000	40	25 / 45	-			10	9.5
	2300	1,000	40	25 / 45	-	*	*	13	12.5
			m/min	mm				mm	mm

PROFILE (1:1)	WIDTH (mm)	BOLT #	# ON WHEEL	ORDER #
	4	558 4000 01	12001	558 4120 01
	6	558 4000 01	13001	558 4130 01
	8	558 4000 01	14001	558 4140 01
	10	558 4000 02	15001	558 4150 01
	13	558 4000 02	16501	558 4165 01

PROFILE (1:1)	WIDTH (mm)	BOLT #	# ON WHEEL	ORDER #
	2	558 4000 01	11002	558 4110 02
	3	558 4000 01	11502	558 4115 02
	4	558 4000 01	12002	558 4120 02
	5	558 4000 01	12502	558 4125 02
	6	558 4000 01	13002	558 4130 02
	7	558 4000 01	13502	558 4135 02
	8	558 4000 01	14002	558 4140 02

PROFILE (1:1)	WIDTH (mm)	BOLT #	# ON WHEEL	ORDER #
	6	558 4000 01	13003	558 4130 03
	10	558 4000 01	15003	558 4150 03

PROFILE (1:1)	WIDTH (mm)	BOLT #	# ON WHEEL	ORDER #
	8	558 4000 01	14403	558 4144 03

PROFILE (1:1)	WIDTH (mm)	BOLT #	# ON WHEEL	ORDER #
	4	558 4000 01	12011	558 4120 11

PROFILE (1:1)	WIDTH (mm)	BOLT #	# ON WHEEL	ORDER #
	8	558 4000 01	16212	558 4162 12

PROFILE (1:1)	WIDTH (mm)	BOLT #	# ON WHEEL	ORDER #
	5.5	558 4000 01	13013	558 4130 13

PROFILE (1:1)	WIDTH (mm)	BOLT #	# ON WHEEL	ORDER #
	9	558 4000 01	13015	558 4130 15

PROFILE (1:1)	WIDTH (mm)	BOLT #	# ON WHEEL	ORDER #
	4	558 4000 01	12001	558 4120 01
	6	558 4000 01	13001	558 4130 01
	8	558 4000 01	14001	558 4140 01
	10	558 4000 02	15001	558 4150 01
	13	558 4000 02	16501	558 4165 01

PROFILE (1:1)	WIDTH (mm)	BOLT #	# ON WHEEL	ORDER #
	2	558 4000 01	11002	558 4110 02
	3	558 4000 01	11502	558 4115 02
	4	558 4000 01	12002	558 4120 02
	5	558 4000 01	12502	558 4125 02
	6	558 4000 01	13002	558 4130 02
	7	558 4000 01	13502	558 4135 02
	8	558 4000 01	14002	558 4140 02

PROFILE (1:1)	WIDTH (mm)	BOLT #	# ON WHEEL	ORDER #
	6	558 4000 01	13003	558 4130 03
	10	558 4000 01	15003	558 4150 03

PROFILE (1:1)	WIDTH (mm)	BOLT #	# ON WHEEL	ORDER #
	8	558 4000 01	14403	558 4144 03

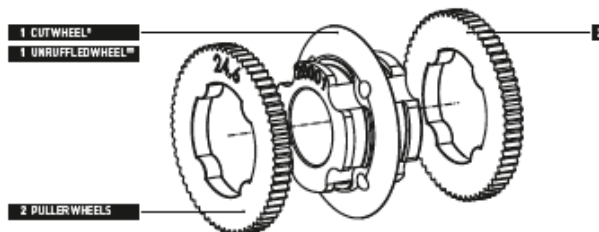

SURFACE	WIDTH (mm)	BOLT #	# ON WHEEL	ORDER #
» CUT WHEELS (FOR PULLER FEED) / SCHNEIDRÄDER (FÜR PULLER-TRANSPORT)²				
45° (sym) *		558 4000 01	20001	558 4200 01
60° (sym) *		558 4000 01	20002	558 4200 02
75° (sym) *		558 4000 01	20003	558 4200 03
Left: 45°; Right: 30° ***		558 4000 01	20005	558 4200 05
Left: 60°; Right: 30° ***		558 4000 01	20006	558 4200 06
Left: 75°; Right: 30° ***		558 4000 01	20007	558 4200 07

SURFACE	WIDTH (mm)	BOLT #	# ON WHEEL	ORDER #
» UNRUFFLED WHEELS (FOR PULLER FEED) / GLATTE SCHWEISSRÄDER (FÜR PULLER-TRANSPORT)²				
unruffled	1.5	558 4000 01	31501	558 4315 01
unruffled	2	558 4000 01	32001	558 4320 01
unruffled	3	558 4000 01	33001	558 4330 01

» PULLER WHEELS / PULLERRÄDER				ORDER #
Set of all puller wheels (x2) / Satz von allen Pullerrädern (jeweils 2x)				558 4900 00
Puller	ø 24.6		ø 24.6	558 4900 01
Puller	ø 24.2		ø 24.2	558 4900 02
Puller	ø 23.6		ø 23.6	558 4900 03
Puller	ø 23.0		ø 23.0	558 4900 04
Puller	ø 20.6		ø 20.6	558 4900 05

# VETRON

## **REMUS MAKİNA**

**MERKEZ** : ANAFARTALAR CAD. NO:600/A-B ÇANKAYA – İZMİR

Tel : 0232 445 02 59 Tel & Fax : 0232 445 07 69

**ŞUBE** : KEMALPAŞA CAD. MTK SİTESİ 1.GİRİŞ NO:6 ALTINDAĞ – İZMİR

Tel : 0232 431 13 34 Tel & Fax : 0232 431 13 35

E-Mail : [info@remusmakina.com](mailto:info@remusmakina.com), [www.remusmakina.com](http://www.remusmakina.com)

## **Xi'an TYPICAL Europe GmbH**

Hertelsbrunnenring 9

D-67657 Kaiserslautern/Germany

Tel: +49 (0) 631 / 316 019 0

Fax: +49 (0) 631 / 316 019 11

E-Mail: [info@typical-europe.com](mailto:info@typical-europe.com)